

THIS DRAWING IS UNPUBLISHED. RELEASED FOR PUBLICATION
 © COPYRIGHT BY TYCO ELECTRONICS CORPORATION. ALL RIGHTS RESERVED.

LOC	DIST	REVISIONS					
G	05	P	LTR	DESCRIPTION	DATE	DWN	APVD
				REV PER ECR-07-024154	10OCT07	JR	TM

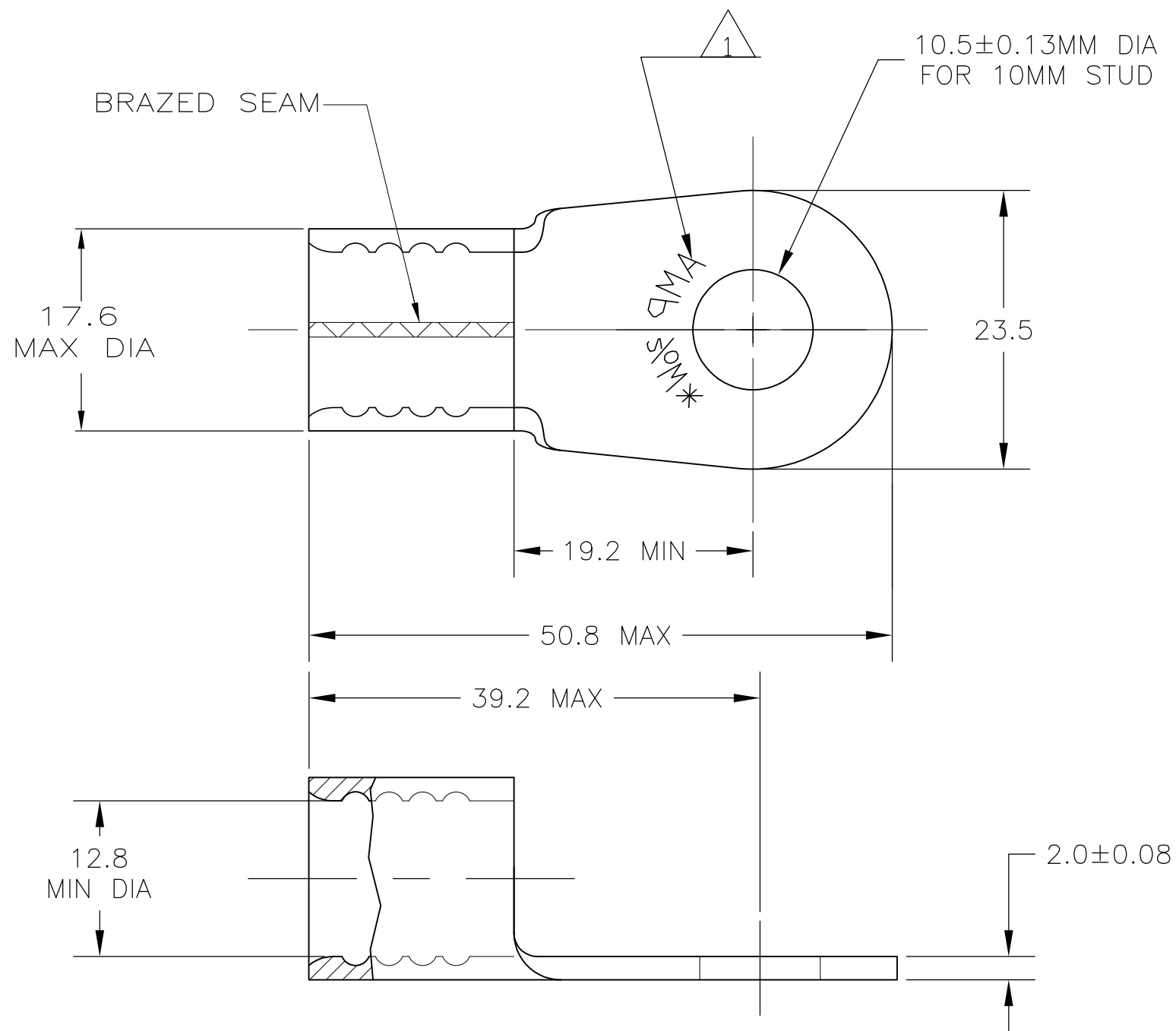

AMP
WIRE RANGE

2/0 AWG
SOLID OR STRANDED

- 1 STAMP "AMP 2/0W*", LOCATED APPROX AS SHOWN
- 2 MAX OPERATION TEMPERATURE IS 170°C MAX
- 3 WIRE CROSS SECTIONAL AREA IS 60.6-76.3mm² [119,500-150,000] CMA.
- 4 COPPER PER ASTM B-152, ANNEALED

160001
PART NO.

THIS DRAWING IS A CONTROLLED DOCUMENT.		DWN	JR RUTH	13JUN05	Tyco Electronics Corporation Harrisburg, Pa 17105-3608			
DIMENSIONS: INCHES		CHK	T MICHIELUTTI	13JUN05	NAME			
TOLERANCES UNLESS OTHERWISE SPECIFIED:		APVD	T MICHIELUTTI	13JUN05	TERMINAL, RING TONGUE, SOLISTRAND			
0 PLC ± -		PRODUCT SPEC		SIZE		CAGE CODE	DRAWING NO	RESTRICTED TO
1 PLC ± 0.2		-		A3		00779	C-160001	-
2 PLC ± -		APPLICATION SPEC		WEIGHT		-		SCALE
3 PLC ± -		-		-		-		2:1
4 PLC ± -		-		-		-		SHEET
ANGLES ± -		-		-		-		1 OF 1
MATERIAL		FINISH		CUSTOMER DRAWING		-		REV
-		TIN PER ASTM B545		-		-		D2